

Leading the way in hazardous
area static control



Online
Inquiry >

Technical Article

New Innovation in Static Grounding Protection Provides Cost Effective Measures for Companies to Control their Static Ignition Fire and Explosion Risks

In U.S., Canadian and European legislation clear references are made to static electricity being a potential source of ignition for operations conducted in flammable and combustible atmospheres presenting a significant and credible risk to the health and safety of employees. Not only does an electrostatic ignition hazard present a health and safety risk, it can cause significant disruption to business operations, in some cases leading to site closures, and result in negative publicity for the company that has suffered from the consequences of a fire or explosion caused by static electricity.

Industry standard guidance that addresses the ignition hazards of static electricity can be followed so that static ignition hazards are identified and the appropriate precautionary measures are put into action. Two leading international guidance documents of specific relevance to the hazardous process industries are the National Fire Protection Association's NFPA 77 "Recommended Practice on Static Electricity" and CENELEC's IEC TS 60079-32-1 "Explosive atmospheres - Part 32-1: Electrostatic hazards, guidance".

Both of these documents identify the range of EX/HAZLOC processes that present electrostatic ignition risks and the practical measures can be adopted to mitigate such risks. The most practical method of avoiding the accumulation, and consequent incendive discharge, of static electricity is the effective grounding and bonding of equipment. Grounding and bonding ensures equipment cannot accumulate electrostatic charge when the equipment is in contact with electrostatically charged liquids, powders and gases or is situated in close proximity to other electrostatically charged objects.

In order to safely transfer electrical charges from electrostatically charged equipment to earth, the most critical factor in the performance of grounding and bonding circuits is to ensure the total electrical resistance present in the path from the equipment requiring static grounding protection to a verified true earth grounding point is known.

Both IEC TS 60079-32-1 and NFPA 77 promote a maximum resistance of 10 Ohms in metal circuits, providing EX/HAZLOC industry participants with a clear benchmark to target as a safety function when grounding and bonding protection against the accumulation of static electricity is a critical fire and explosion prevention measure.

Target 10 Ohms

The Earth-Rite® MULTIPOINT II is the kind of system equipment specifiers and end users alike can adapt for a wide range of EX/HAZLOC processes that require active static grounding of metal equipment. Whether the metal equipment requiring static grounding protection is a railcar, an IBC (tote), drum or potentially isolated parts of interconnected process equipment, the Earth-Rite MULTIPOINT II will only indicate a positive ground status if the electrical resistance in the grounding circuit for the equipment is 10 Ohms or less.

One of the primary cost advantages of the Earth-Rite MULTIPOINT II is its ability to actively monitor the ground status of up to eight discrete items of equipment. Whereas one standard grounding system comprising an interlock function is typically needed for a single item of equipment, the Earth-Rite MULTIPOINT II's ability to monitor eight items of equipment, simultaneously, means that economies of scale can be achieved when the total installed cost of a project is calculated.

The Earth-Rite MULTIPOINT II consists of a monitoring control unit that features an array of red and green LED indicators that verify when the equipment in need of static grounding protection has a resistance to a verified true earth grounding point of 10 Ohms or less. In addition to the LED indicators located in the monitoring control unit, equipment operators can refer to independent remote indicator stations that can be mounted closer to the process hazard. Each indicator station provides operators with a visual "GO / NO GO" reference that informs them when the resistance in the static grounding circuit is low enough (less than 10 Ohms) to proceed with the operation.

Demonstrating its installation flexibility in the following application the system is specified to ground four mixing stations (1 to 4) and two filling stations (5 and 6). Each mixer is interlocked with an individual relay corresponding to the equivalent ground monitoring channel so that if the resistance between the grounding clamp's connection to the drum and the verified earthing point exceeds 10 Ohms the mixer will not operate. Channels 5 and 6 are grouped via the system's group relay so that if either drum is not grounded the pump feeding the filling station is shut down immediately, thereby stopping the delivery of electrostatically charged liquids to the drums.

Economies of scale are realised when compared with the total purchasing cost of six individual generic static grounding systems and there are several reasons why installation costs are minimised when compared to generic grounding solutions.

The remote indicator stations are powered with intrinsically safe circuits that are fed directly from the monitoring control unit. This is more cost effective than specifying expensive Ex(d)/XP approved indicator stations that would need to be powered with line power in the 230 V to 110 V AC range. In addition to the reduced cabling and purchase cost of the Earth-Rite MULTIPOINT II indicator stations, they consume much less power than line powered indicator stations.

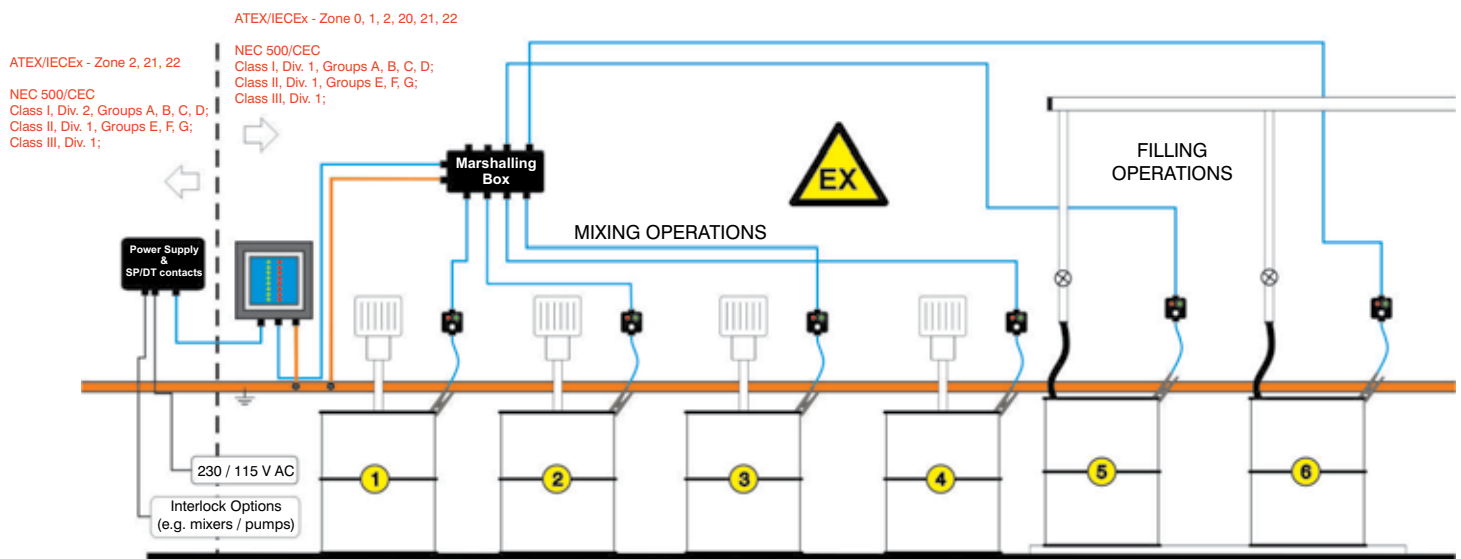

The Earth-Rite® MULTIPOINT II's monitoring control unit and remote indicator stations can be installed in Class I, Div.1 atmospheres. The power supply unit can be installed in Class I, Div. 2 atmospheres.

Depending on the number of monitored channels required for a particular installation a flexible dip-switch located on the monitoring control unit's PCB can be used to switch on and off specific monitoring channels. The power supply PCB also utilises a dip-switch which is used for the group relay function. In addition to the eight dry contacts provided as standard for each monitored channel, the group relay function enables specifiers utilise two additional dry contacts so that these relays are energised only when all of the channels selected as part of the group displays a resistance of 10 Ohms or less for each individual item of equipment. This means interlocked equipment will only be activated on condition that all grouped monitoring channels have equipment grounded to a resistance of 10 Ohms or less.

Although there are effectively 10 relays located on the power supply PCB that can interface with the monitoring control unit's PCB, communication between both PCBs is achieved via CAN bus. The CAN bus wiring, in conjunction with the Intrinsically Safe power supplied to the monitoring control unit, means that four conductor cabling is all that is required between both units. This mitigates variations in cabling specifications and allows for a much more accurate prediction of cabling costs.

Earth-Rite MULTIPOINT II applications are not limited to examples like the drum mixing and filling process above. Process hazards ranging from railcar loading operations through to powder processing equipment can have their static ignition hazards reduced with the Earth-Rite MULTIPOINT II.



In this example the Earth-Rite MULTIPOINT II is configured to ground multiple interconnected components for a fluid bed dryer system. The marshalling box feeds seven channels out to seven permanent ground connection points. The connection points may be disconnected for routine cleaning, inspection and maintenance. Channels 1 to 7 are grouped together to provide a single output contact controlling the flow of powder into the fluid bed dryer. Channel 8 utilises an external ground status indicator station to provide the operator with a visual confirmation that the mobile bin is grounded prior to filling.

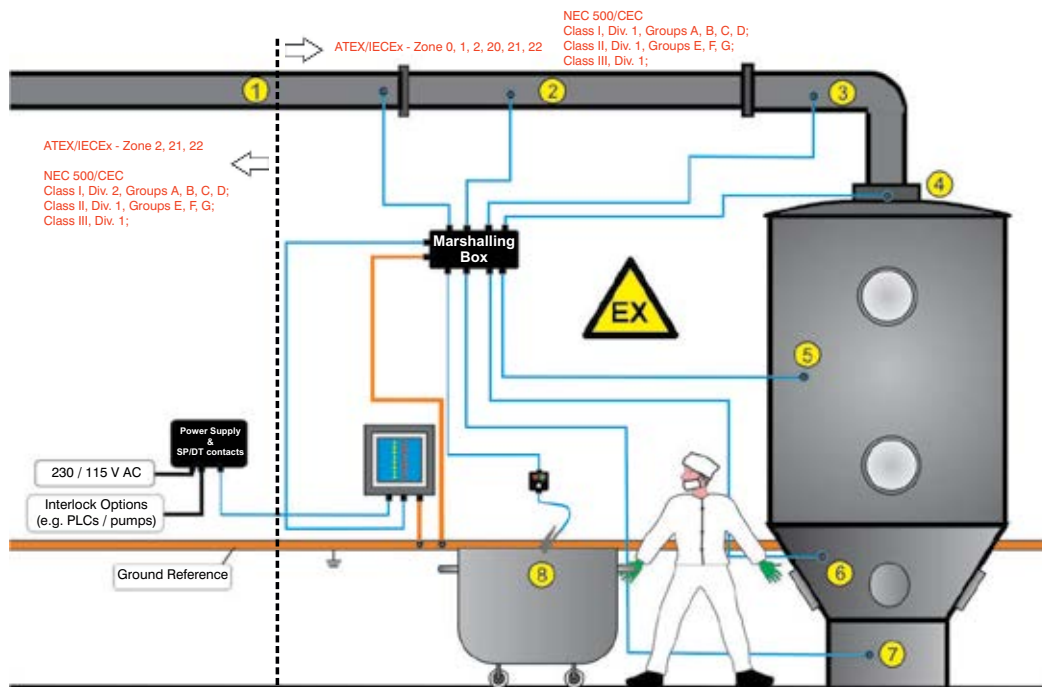

The Earth-Rite MULTIPOINT II's monitoring control unit, remote indicator stations and power supply unit can be installed in Class II, Div.1 atmospheres. This configuration enables companies employ 24/7 monitoring of interconnected process equipment. This is particularly important when equipment is regularly disassembled and reassembled for cleaning and maintenance activities.

Reliability

The Earth-Rite MULTIPOINT II's software is written to the internationally recognised MISRA C protocol which has proven its reliability in the execution of safety functions across automotive, aerospace, medical, telecoms and industrial applications. Both the monitoring control unit and the power supply unit have watchdog circuits that activate a fail-safe relay located on the power supply unit should the software of the embedded systems on either unit stop running. In addition to the watchdog circuits of both units, the monitoring control unit monitors the permissive threshold of each monitored channel so that if the permissive resistance range rises outside 0 to 10 Ohms, e.g. a permissive condition is achieved with a resistance of 16 Ohms, the fail-safe relay is activated. The purpose of the fail-safe relay is to ensure interlocked equipment does not continue to operate in the event that any of the equipment requiring active static grounding protection in the hazardous area may not be grounded.

Hazardous area certified

The monitoring control unit and remote indicator stations are cCSAus approved for installation in Class I, Div. 1; Class II, Div. 1 and Class III atmospheres and ATEX / IECEx certified for installation in Zone 0 / Zone 20 atmospheres. The power supply unit is cCSAus approved for installation in Class I, Div. 2; Class II, Div. 1 and Class III atmospheres and ATEX / IECEx certified for installation in Zone 2 / Zone 21 atmospheres. The Earth-Rite MULTIPOINT II has been assessed in accordance with IEC 61010 Safety Requirements for Electrical Protection.

If you have any questions on this case study e-mail [Newson Gale](mailto:Newson.Gale).

If you would like to learn more about the Earth-Rite MULTIPOINT II follow this link to the [product webpage](#).

Copyright Notice

The website and its content is copyright of Newson Gale Ltd © 2020. All rights reserved.

Any redistribution or reproduction of part or all of the contents in any form is prohibited other than the following:

* you may print or download to a local hard disk extracts for your personal and noncommercial use only
* you may copy the content to individual third parties for their personal use, but only if you acknowledge the website as the source of the material

You may not, except with our express written permission, distribute or commercially exploit the content. Nor may you transmit it or store it in any other website or other form of electronic retrieval system.

Right to change

This document provides general information only and may be subject to change at any time without notice. All information, representations, links or other messages may be changed by Newson Gale at any time without prior notice or explanation.

Newson Gale is not obliged to remove any outdated information from its content or to expressly mark it as being outdated. Please seek the advice of professionals as necessary regarding the evaluation of any content.

Disclaimer of liability

The information provided in this Technical Article is provided by Newson Gale without any representations or warranties, expressed or implied, as to its accuracy or completeness. The liability of Newson Gale for any expenses, losses or actions incurred whatsoever by the recipient as a result of the use of this Technical Article shall be excluded.

Leading the way in hazardous area static control



5/5

United Kingdom

Newson Gale Ltd
Omega House
Private Road 8
Colwick, Nottingham
NG4 2JX, UK
+44 (0)115 940 7500
groundit@newson-gale.co.uk

United States

IEP Technologies LLC
417-1 South Street
Marlborough, MA 01752
USA
+1 732 961 7610
groundit@newson-gale.com

Deutschland

IEP Technologies GmbH
Kaiserswerther Str. 85C
40878 Ratingen
Germany
+49 (0)2102 58890
erdung@newson-gale.de